

TE2SCADA



Distribution automation challenges





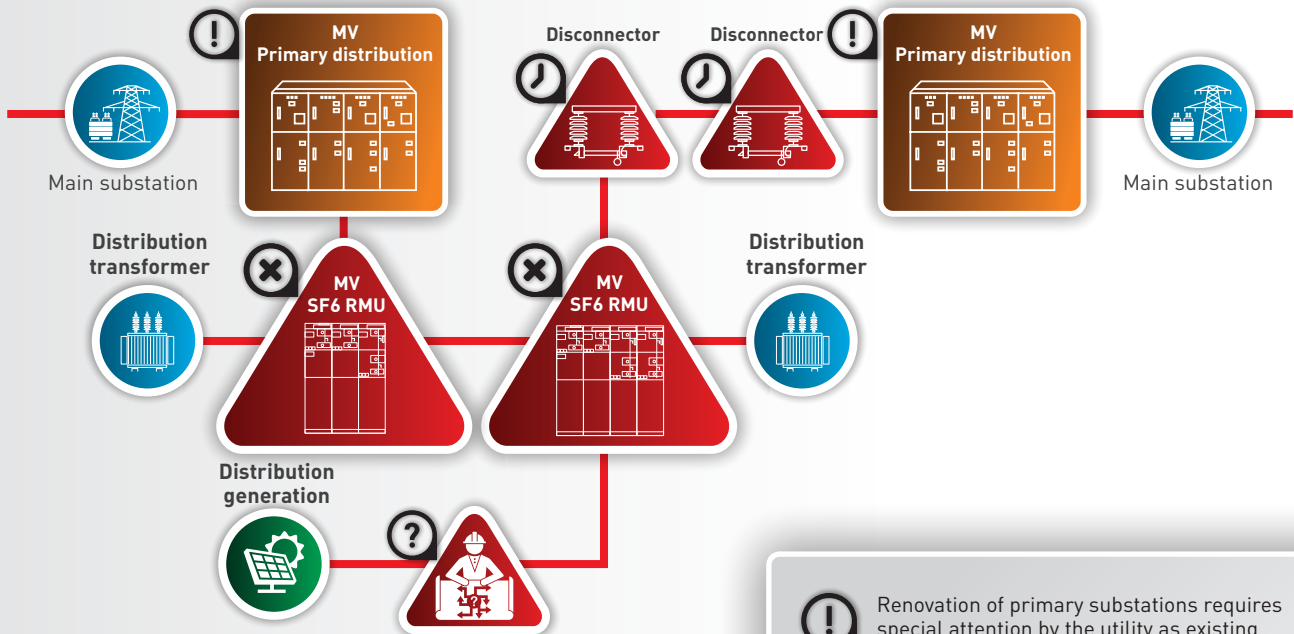

No monitoring and remote control over the distribution network without the use of SCADA.



Long list of potential environmental and health risks associated with the use of obsolete equipment which is not suited for Smart Grid applications.



Long-time power outages and high maintenance cost of the existing non-automated system.

-  Renovation of primary substations requires special attention by the utility as existing switchgear is often nearing the end of its intended operating life. It requires a feasible strategy to replace or upgrade the existing equipment with the state-of-the-art circuit breakers that will expand the automation capabilities of distribution network.
-  Manually operated disconnectors are not equipped with any automation capabilities and require maintenance personnel to restore power after long outage periods.
-  Old generation non-extensible RMU can no longer meet feeder automaton requirements
Use of environmentally and health hazardous SF6 is associated with the need for:
 - Continuous monitoring of SF6 degradation;
 - Special regulations for recycling of hazardous waste.
-  Global shift toward renewable energy is already underway. How to handle integration of distributed energy resources in the most efficient way?

Distribution automation with TE2SCADA

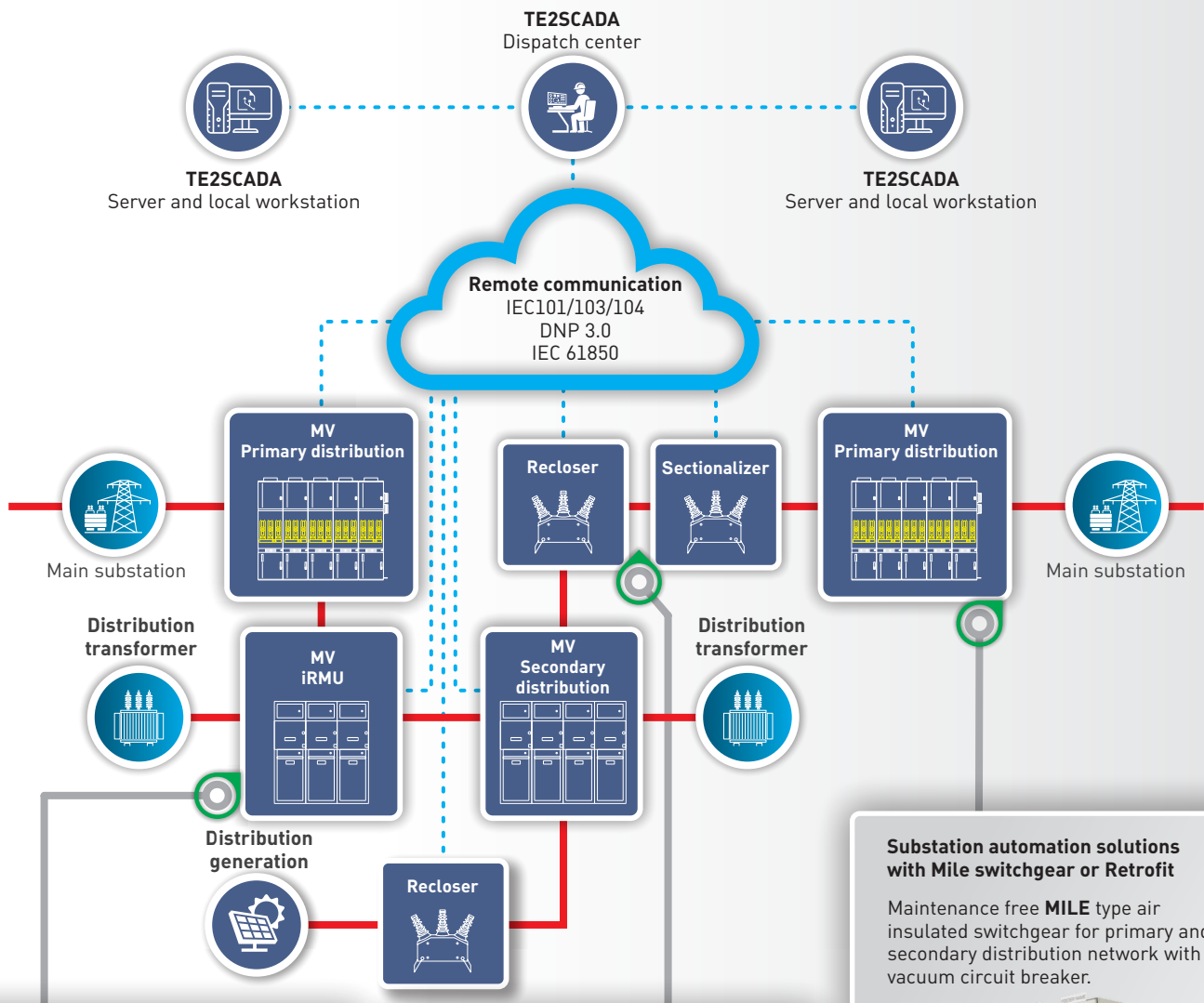

Distribution automation with SCELL switchgear and iRMU

New alternative to SF₆ gas-insulated RMU.
Maintenance free compact **SCELL** type air insulated switchgear for secondary distribution network with vacuum circuit breaker.

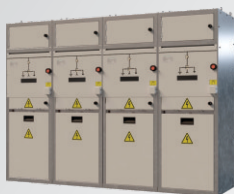

SCELL Switchgear:

- TLF/IED protection
- Remote control up to 5 panels
- Communication: IEC 104/DNP3.0

SCELL iRMU:

- IED protection
- Customized RTU system depending on the application
- Communication: IEC 104/DNP3.0/IEC 61850 (option)
- Measuring (voltage, current, direction)
- Power-quality monitoring
- Auxiliary power supply system

Distribution automation with Recloser and sectionalizers

Maintenance free switches with complete measurement system, advanced protection and embedded RTU:



- Advanced IED protection (ABR, Synchro-check, Fault locator)
- Innovative sectionalizer algorithms
- Communication: IEC 104/DNP3.0/Modbus
- Complete measuring system (4x current channels, 6x voltage channels, direction)
- Power-quality monitoring
- Embedded auxiliary power supply system

Substation automation solutions with Mile switchgear or Retrofit

Maintenance free **MILE** type air insulated switchgear for primary and secondary distribution network with vacuum circuit breaker.



Alternative solution: innovative plug and play switchgear **Retrofit** solution with vacuum circuit breaker.



Advanced flexible and reliable RTU systems for substation automation:

- IED protection
- Communication: IEC 101/IEC 103/IEC 104/DNP3.0/IEC 61850 (option)
- Measuring (voltage, current, direction)
- Power-quality monitoring
- Auxiliary power supply system

Presentation

The TE2SCADA system is designed for real-time monitoring and control of primary and secondary equipment in power distribution systems. It provides all the functionality that is expected from a SCADA system, allowing the operator to safely and effectively interact with protection and control IEDs (Intelligent Electronic Device) achieving the maximized efficiency and reliability of the grid.

TE2SCADA is compatible with any IED supporting standard industrial interfaces which enables an electric utility to integrate all its equipment into the same system.

TE2SCADA supports an extensive range of standard communication protocols and open interfaces, such as IEC 60870-5-101/103/104, Modbus RTU/TCP and DNP3.0 RTU/TCP. It also supports OPC DA 2 and OPC UA server and client interfaces which enables easy integration with application specific systems and devices.

For a different kind of reporting, TE2SCADA offers SQL export of any stored data from the project database to, for example, Excel or similar format. Extensive tools allow users to create measurement, outage and energy reports to evaluate the reliability of the distribution network based on such parameters like SAIDI, SAIFI, CAIFI, CAIDI and others.

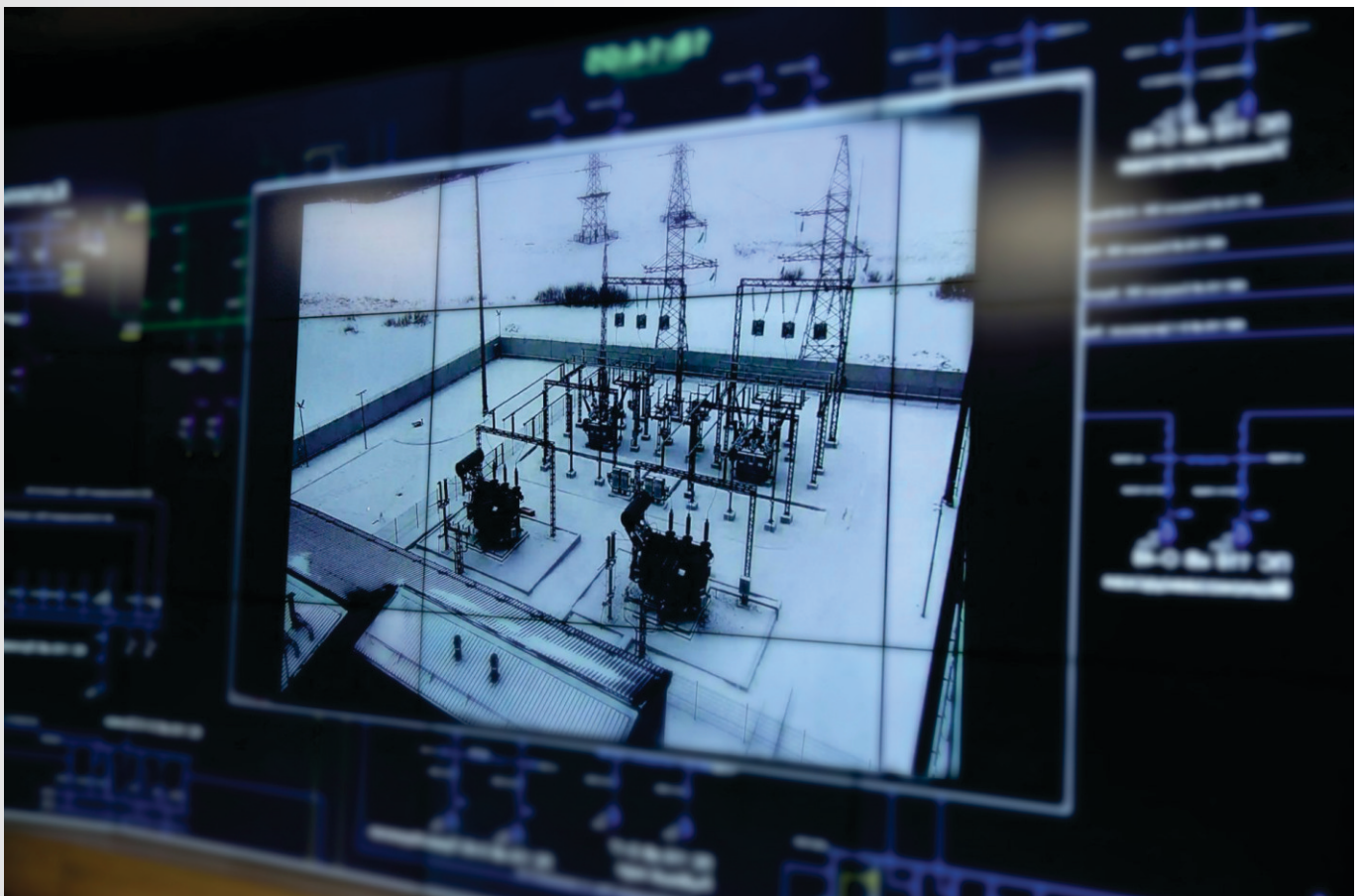

TE2SCADA provides constant grid supervision to detect any failures, which reduces the need for scheduled and emergency maintenance.



Reducing maintenance costs

The advanced distribution automation and management functions reduce outage time from hours to minutes without the involvement of field personnel.



Minimizing outage time

Redundant architecture enhances availability and increases the reliability of the system. User-friendly and functional interface guarantees safe and error-free operation.



Maximum reliability and ease of use

Developed to meet industrial standards for data communications such as IEC 60870-5-101/103/104 and cyber security standards such as IEC 62351.



Standards compliance



Features

TE2SCADA is based on the EnLogic open-source software platform designed for embedded controllers widely used in grid automation. It supports Linux, WinCE, Win32/64 and eCos platforms. The system implements the client-server architecture which allows creating a multi-server automation system designed to support a large number of workstations. At the same time, TE2SCADA is highly scalable and can be used for deployment of low-end single systems up to fully-fledged distributed monitoring and control systems. This means that data acquisition servers, databases and operator workstations can be installed either on single or multiple computers which allows implementing multi-scale grid automation projects.

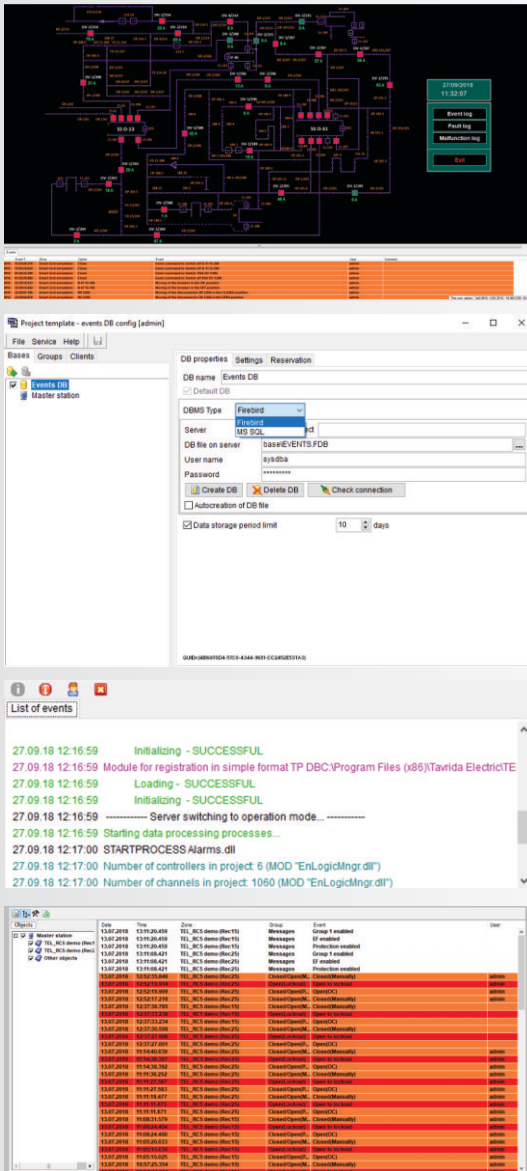

HMI (Human Machine Interface) – the core component designed to display the power distribution system with real-time data acquisition. The interface allows operators to remotely monitor and control equipment and to process historical data.

Flexible and easy user-configurable HMI allows creating extensible mimic diagrams with thousands of objects. Standard visualization features such as dynamic coloring provide operators a quick access to information about the powered and un-powered sections of the network and state of equipment (Closed/Open/Earthed) for circuit breakers, load break switches, disconnectors and other objects. All alarming objects are highlighted for clear identification and quick reaction. The dynamic coloring combined with a full object control ensure the safe and correct operation of the system.

Database (DB) – Microsoft SQL Server and Firebird SQL-based database management system is designed to archive thousands of values and records over long time periods in an accurate and easily accessible way. The ability to export data from a SQL Server database to a Microsoft Excel worksheet, HTML or other text formats allows a user to create various customized reports. The backup and restore features provide an essential safeguard for protecting critical data stored in the database.

Data Acquisition Server (DAS) is used to connect remote objects to TE2SCADA. It coordinates and sends commands to the connected object to adjust parameters and provides the time synchronization feature which allows accurate time-tagging of all events. Collected data is stored in the database.

Event logging module allows users to easily access and process information about faults, switching operations and various historical trends which creates a strong basis for accurate system performance analysis.

Alarm module is designed to signal any failures, malfunctions or warnings which demand the operator's attention to abnormal system conditions requiring action.

Power monitoring – optional module for real-time power monitoring which ensures that the system fulfils the requirements set for power quality. All the important information (THD, active/reactive/apparent power and energy, power factor and others) is stored in the database and can be easily converted into the meaningful report.

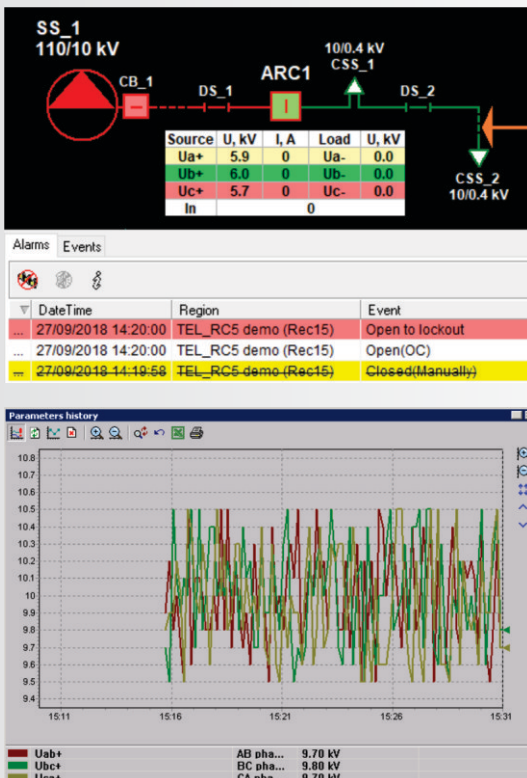

Technical summary

Platform and architecture

EnLogic open-source software for industrial applications

Supported platforms: WinCE, Win32/64, eCos

Microsoft SQL Server and Firebird SQL-based database management system

High performance and reliability

System self-supervision

Multi-scale solutions for grid automation

Communication interfaces

Supported communication protocols: IEC 60870-5-101/103/104, Modbus RTU/TCP, DNP3.0 RTU/TCP

Supported open interfaces: OPC DA 2 and OPC UA

Standard libraries for simple integration with widely-used IEDs

Power distribution monitoring and control

Real-time monitoring and full control over remote objects

Outage management and network reconfiguration

Graphical display with dynamic coloring and visualization of alarming objects

System performance analysis

Advanced data logging and refinement

Power-quality monitoring: THD, active/reactive/apparent power and energy, power factor, etc.

Extensive reporting facilities: event profile, measurements, outage reports

Network security

Encryption and security protocols such as VPN (OpenVPN, IPsec, GRE, L2TP, PPTP), DNP3.0 secure authentication

Malware security protection

Role-based user authorization and access control

Event logging and reporting



TE2SCADA application example

GRID AUTOMATION WITH RECLOSERS

Reclosers provide protection from various faults, including: short circuits, earth faults, high impedance earth faults, broken wires, islanding, incorrect tap changer operations, network overload and over- or under-generation.

Embedded IED with the RTU (Remote Terminal Unit), protection and metering functions makes the recloser the perfect solution for grid automation projects. Reclosers allow utilities to implement Smart Grid philosophies and deploy advanced self-healing FDIR (Fault Detection, Isolation and Restoration) systems.



Rec15/25 Automatic Circuit Recloser:

- State of the art Outdoor Switching Module
- Sophisticated control and protection for Smart Grids
- x6 combined current and voltage sensors built-in
- Maintenance free
- Lightest weight
- Plug & Play design
- 55,000 installations worldwide

Parameter	Rec15	Rec25
Rated voltage (Ur)	15.5 kV	27 kV
Rated continuous current (Ir)	630 A	630 A
Rated short-circuit breaking current (Isc)	16 kA	12.5 kA
Rated frequency (fr)	50/60 Hz	
Operating cycles, rated current (CO-cycles)	30 000	
Operating cycles, breaking current (CO-cycles)	200	
Closing time, not more than	50 ms	
Opening time, not more than	25 ms	
Rated operating sequence	O-0.1s-CO-1s-CO-1s-CO	
Outdoor Switching Module weight	68 kg	72 kg
Service life	30 years	

TECHNICAL SOLUTION

TE Energy offers utilities to easily integrate all existing and new reclosers with the TE2SCADA system, which continuously monitors the system and processes commands executed by the operator.

Remote control and monitoring functions are implemented over HSUPA/HSDPA/UMTS/EDGE/GPRS network using IEC 60870-5-104 or DNP3.0 communication protocol. The recloser uses the embedded RTU and highly reliable and secure LTE router RUT95x specially developed for industrial applications. The RUT95x delivers high performance, mission-critical wireless communication and GPS coordination. The dual SIM feature provides redundant cellular connection in a critical situation. The external LTE/GPS/WIFI outdoor antenna attached to the recloser cubicle provides the best signal and possibility to remotely configure the router and recloser settings over the wireless network.



Main features

Standard solutions for simple integration with the TE2SCADA system

Maximum performance through the special TE2SCADA design developed to provide full control over all the recloser functions

Parallel communication channel to access and configure the recloser settings

Possibility to use multiple data channels for communications

Secure data channel protects information against unauthorized access

RUT955 specification

Ethernet		Hardware	
<ul style="list-style-type: none"> ■ IEEE 802.3, IEEE 802.3u ■ 3 x LAN 10/100 Mbps Ethernet ports ■ 1 x WAN 10/100 Mbps Ethernet port ■ Supports auto MDI/MDIX 		<ul style="list-style-type: none"> ■ High performance 560MHz CPU with 128MB DDR2 memory ■ 2 pin industrial DC power socket ■ 4 pin industrial socket for 2/4 wire RS485 ■ 10 pin industrial socket for inputs/outputs ■ DB9 socket for full-featured RS232 ■ USB A socket for external devices ■ 2 x SMA for LTE, 1 x SMA for GPS, 2 x RP-SMA for WiFi ■ Indication LEDs 	
WiFi			
<ul style="list-style-type: none"> ■ IEEE 802.11b/g/n, 2.4 GHz, 2x2 MIMO ■ 64/128-bit WEP, WPA, WPA2, WPA&WPA2, EAP-PEAP ■ SSID stealth mode and access control based on MAC address 			
Electrical, Mechanical & Environmental		Software	
<ul style="list-style-type: none"> ■ Dimensions (H x W x D) ■ Weight ■ Power supply ■ Power consumption ■ Operating temperature ■ Operating humidity 	<ul style="list-style-type: none"> 80 mm x 106 mm x 46 mm 265 g 9 – 30 VDC < 7 W -40 °C to 75 °C 10 % to 90 % non-condensing 	<ul style="list-style-type: none"> ■ OpenVPN, IPsec, GRE, L2TP, PPTP, PPPoE, VRRP ■ Backup WAN, dynamic DNS, SNMP trap monitoring ■ Event logging ■ Firewall, web filter ■ RS232/485 serial console, RS232/485 over IP ■ SMS/e-mail control and indication ■ Firmware update via WebUI, configuration backup 	



References



CEDIS Montenegrin Electricity Distribution System

In partnership with BB Solar, our TE2SCADA solution enhances 10kV distribution automation with 25 reclosers installed across key overhead lines: Dupilo, Mrkojevići, Virpazar – Ostros, Gornja Morača, Rovac, and Skrbuša. With a centralized dispatch center at Breza and Topolica substations, TE2SCADA improves grid reliability by reducing SAIDI indices and minimizing Energy Not Supplied (ENS). The second phase of the project, involving approximately 100 installations, is scheduled for completion in 2025.

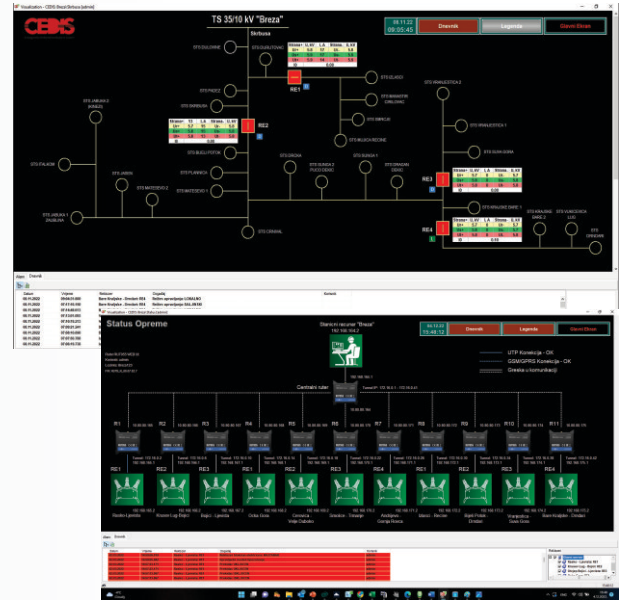

The Egyptian Electricity Holding Company Egypt

We are a leading SCADA provider in Egypt, with nearly 1,000 reclosers successfully integrated into the TE2SCADA system. Our key customers include major secondary distribution companies:

- North Delta Electricity Distribution Company (NDEDC); 200 objects
- South Delta Electricity Distribution Company (SDEDC); 180 objects
- Middle Egypt Electricity Distribution Company (MEEDC); 300 objects
- Upper Egypt Electricity Distribution Company (UEEDC); 80 objects
- Beheira Electricity Distribution Company (BEDC); 160 objects

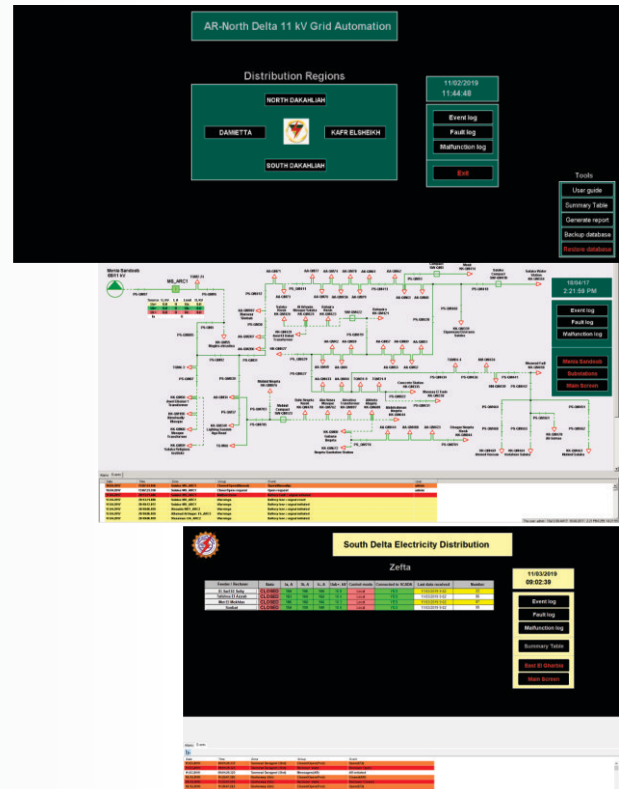

Reference summary

- Experience and knowledge of complex grid automation
- More than 10 turnkey large-scale SCADA government-backed projects
- More than 50 small-scale SCADA projects
- Over 2.5 thousand of objects integrated in SCADA

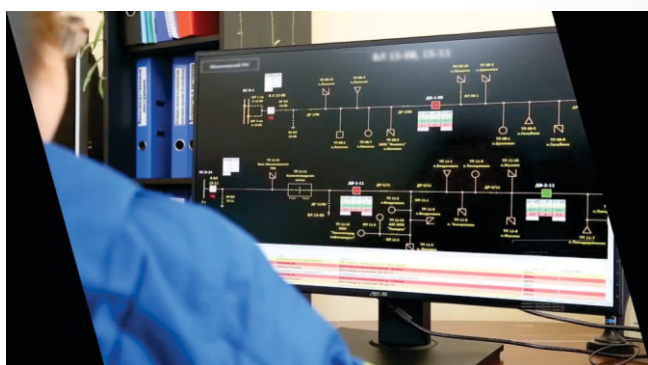

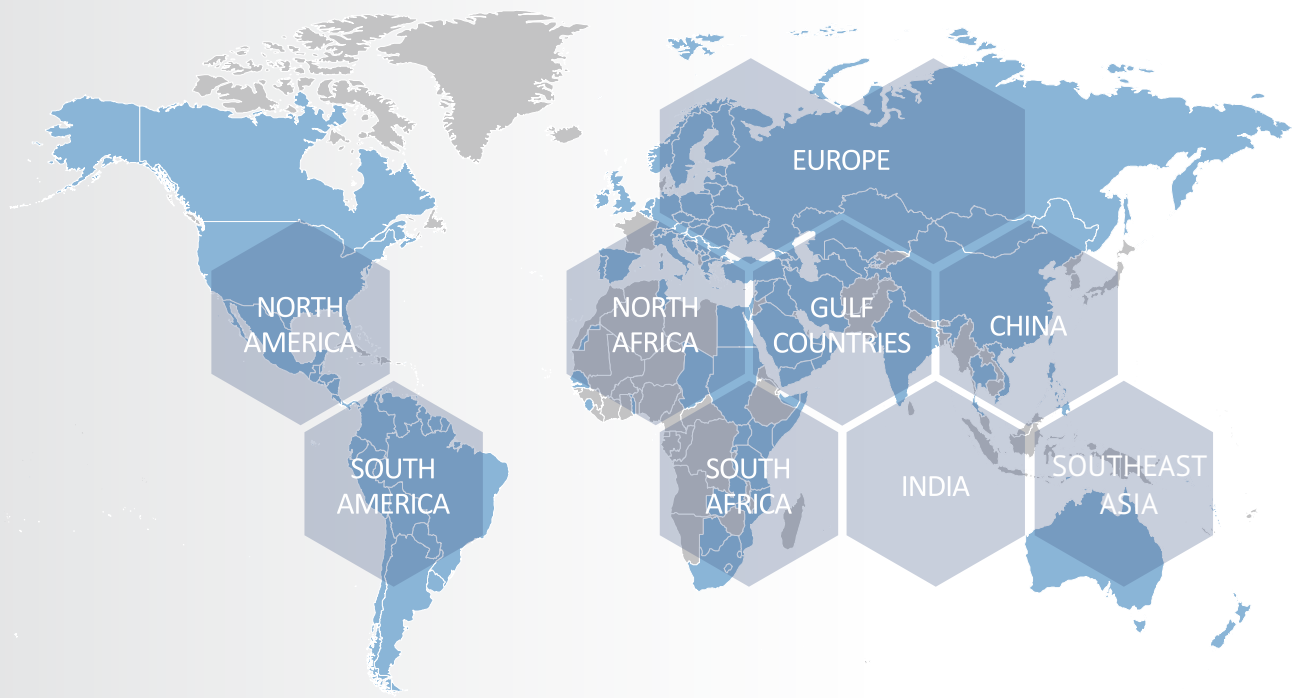

TE² Energy

On time with Confidence

14, Visase str,
Tallinn 11415 Estonia

Tel.: +372 606 47 57

E-mail: info@te2.energy

Web: www.te2.energy

rev. 2. 17.3.2025

This document is copyright and is intended for users and distributors of TE Energy products. It contains information that is the intellectual property of TE Energy and this document or any part thereof, should not be copied or reproduced in any form without the prior permission of TE Energy. TE Energy applies a policy of ongoing development and reserves the right to change products without notice. TE Energy does not accept any responsibility for loss or damage incurred as a result of acting or refraining from action based on information in this document.